

Sikorsky® S-300CBI™ Piston Helicopter
Simply the best for training and personal use

Sikorsky Global Helicopters

A Sikorsky Company

Sikorsky® S-300CBI™ Piston Helicopter

Simply the best for training and personal use

The thrill of flying helicopters economically and to professional standards is what the S-300CBI™ helicopter is all about. Point designed for the training role, it has a proven record of success and multi-mission capability. Exceptional value and outstanding flight characteristics set the S-300CBI™ helicopter apart.

Features include:

1. Most cost effective and mission effective training helicopter.
2. Spacious cabin with the highest loading capacity in its class.
3. Responsive and forgiving flight handling characteristics.
4. Fuel injected, 180 horsepower engine and Schweizer's innovative STAR system.
5. Large power reserve.
6. Tri-level energy absorption system.
7. Excellent autorotational characteristics.
8. Standard aircraft fully equipped for training and personal use.
9. Field replaceable components for easy maintenance and less down time.
10. Mandatory retirement times for all life-limited components exceed 4,000 hours.

Simply the best for training and personal use.

- Fuel injection eliminates the need for carburetor heat and removes the risk of carburetor ice. Throttle correlation and engine response is smooth and immediate.
- STAR system provides engine start-up overspeed protection, automatic rotor engagement, and low rotor/engine RPM warning signals.
- With the 4000 hour splined main rotor driveshaft and 8000 hour splined main rotor hub, the life limits of all mandatory retirement components are now 4,000 hours or more.
- Standard equipment includes the basic avionics and accessories required by most operators.
- Spacious cockpit, outstanding flight handling characteristics, and 648 pounds of useful load make the S-300CBI™ helicopter a pleasure to fly.
- For most commercial operators, the S-300CBI™ will provide a lower cost of ownership than any other helicopter.
- The S-300CBI™ helicopter comes with a comprehensive warranty backed by our commitment to excellent product support.

The S-300CBI™ helicopter provides outstanding performance, rugged dependability, and inherent value.

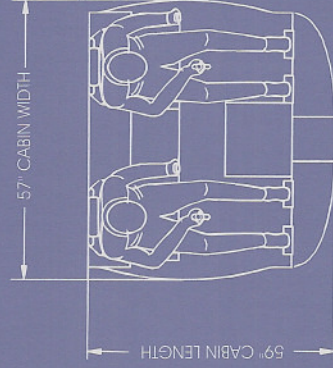
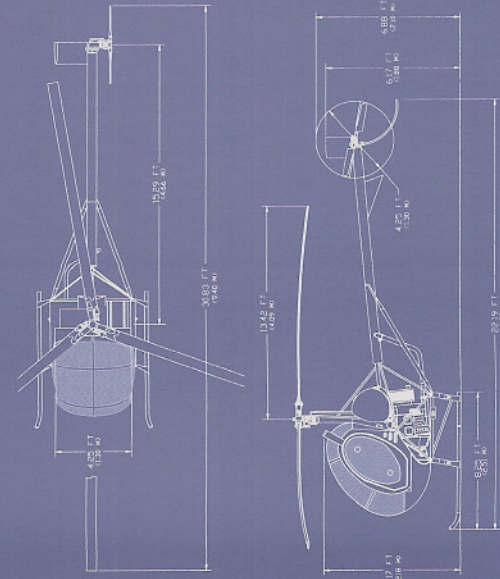

Cockpit features

- 360° visibility
- Conventional flight controls
- Adjustable anti-torque pedals

Performance

VNE (Kias) at Sea Level	94 knots	174 km/hr
Cruise Speed	80 knots	148 km/hr
Maximum Endurance (32 gal)	3.0 hrs	3.0 hrs
Maximum Endurance (64 gal)	6.0 hrs	6.0 hrs
Maximum Range (32 gal)	225 nm	417 km
Maximum Range (64 gal)	440 nm	815 km
Hover Ceiling IGE @ 1600 lb	7000 ft	2,133 m
Hover Ceiling IGE @ 1600 lb	4800 ft	1,463 m

Dimensions

Height (overall)	3.72 ft	2.65 m
Length (overall)	30.83 ft	9.40 m
Fuselage Length	22.19 ft	6.76 m
Landing Gear Tread	5.54 ft	1.99 m

Weight

Empty Weight	1,102 lb	500 kg
Gross Weight	1,750 lb	794 kg
Useful Load	648 lb	293 kg

Powerplant

Textron Lycoming HIO-360 G1A Engine	
Maximum Takeoff	180 shp
Maximum Continuous	180 shp

Rotor System

Main Rotor Diameter	25.83 ft	8.18 m
Main Rotor Disk Area	565 sq ft	52.49 sq m
Main Rotor RPM	471 rpm	471 rpm
Tail Rotor Diameter	4.25 ft	1.30 m

Fuel

Standard Capacity	32 gal	192 lb	87 kg
Auxiliary Fuel	64 gal	384 lb	174 kg

Seating Capacity

Standard Right Hand PIC	2
Optional Left Hand PIC	3

Sikorsky Global Helicopters

A Sikorsky Company

Light Helicopter Division

Elmira, NY USA

+1 (607) 739-3821 www.sikorsky.com